



# giri brothers

Since 1973

Specialist in Quality Weighing, Counting and Billing Machines

## DCS – CRANE SCALE

The CIBI DCS model crane scales are tried and tested, widely used crane scales. They come with rugged, aluminium ergonomic design. Its bright red 30 mm display gives better visibility at heights. Its built-in rechargeable battery gives a back up for up to 16 hours. It comes with a remote control, with options like Hold, Tare, Zero etc.,. It is approved by weights and measures, department of legal metrology. If you are looking for a simple crane Scale, just opt for this. Best buy guaranteed.



### Features

- Cast aluminium housing for maximum protection
- Easy-to-read 30mm LED display
- Standard remote controller
- Battery operated with low battery indication
- On, Off, Zero, Tare and Hold (Manual or Automatic) functions

### Optional

You can opt for a Wireless Hand Held Indicator with printout. It displays the real time weight on the display. It can record weight, and can be transferred to your PC or Even ERP. The print out gives an output of Date /Time Serial number or Batch number, accumulated weights etc. It has a wide variety of reports

### Features

- 1) 5.5 Inch Touch Display
- 2) Wifi, Bluetooth
- 3) 2gb Ram 16gb Memory
- 4) Built in Giri 4.0 Softwares
- 5) Can Pair with LABEL /Barcode Printers.



### Application

INDUSTRIES

New No.24 (old 51), Rajaji Salai, Chennai - 600 001,INDIA

Phone: 044-2522 5401. Mobile :+91-98414 36535. Email : [sales@giribrothers.in](mailto:sales@giribrothers.in)

Web : [www.giribrothers.in](http://www.giribrothers.in)



# giri brothers

Since 1973

## Specialist in Quality Weighing, Counting and Billing Machines

### Specification

MAKE	CIBI						
Model	1DCS	2 DCW	3 DCW	5 DCW	10 DCW	15 DCW	20 DCW
Weighing Capacity	1000kg x 0.5kg	2000kg x 1kg	3000kg x 1 kg	5000kg x 2kg	10000kg X 5kg	15000kg X 5kg	20000kg X 10kg
Maximum Tare	Full Tare						
Display Digit	LED (1.2 inch)						
Operating Power	DC 6V						
Power Source	AC 110/ 120/ 220/ 240V, 50/ 60Hz						
Power Consumption	1W						
Operating Temperature	-10°C ~ +40°C						
Dimensions (mm)	230(W) x 370(D) x 380(H)		230(W) x 370(D) x 474.5(H)		230(W) x 370(D) x 518.5(H)		
Product Weight	15kg		17kg		20kg		

### Dimension

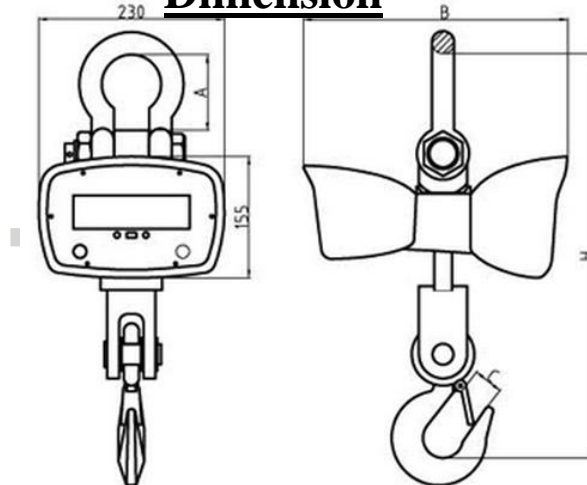

MODEL	A(mm)	B(mm)	C(mm)	H(mm)	N.W.(kg)
DCS-1	67	350	33	450	13.5
DCS-2	67	350	33	450	13.5
DCS-3	95	350	40	510	17
DCS-5	113	365	50	625	26
DCS-10	122	365	60	760	40
DCS-15	144	365	70	835	55
DCS-20	166	365	85	900	68

New No.24 (old 51), Rajaji Salai, Chennai - 600 001,INDIA

Phone: 044-2522 5401. Mobile :+91-98414 36535. Email : [sales@giribrothers.in](mailto:sales@giribrothers.in)

Web : [www.giribrothers.in](http://www.giribrothers.in)

C  
I  
B  
I